

Bring on the
heavyweights the
GIANT Series
can take the hit

TESTED TO
10,000
CYCLES

Ideal for panels of up to
1000lb.



3" wheels and precision bearings
reduce rolling resistance



**ANTHONY
INNOVATIONS**
Moving Doors And Windows Forward

To discuss your requirements contact us on:
salesna@anthonygroup.net

Designed to withstand high load capacity

Features and Benefits:

- 500lb load capacity enables you to build larger, heavier doors of up to 1000lb.
- Made with pressed metal components, forged rivets and axels, to ensure product remains robust under load.
- Polymer wheels reduce noise and minimise track wear, guaranteeing system performance over time.
- Precision bearing components reduce operating force.
- Single bogey carriage ensures balanced load distribution which guarantees smooth panel operation.
- Retains structural integrity during and after installation which ensures product durability and longevity.
- Optional thrust bearing upgrade available for easier adjustment under load.

Sturdy design:

AAMA 906 certified for durability and performance, the GIANT Series provides effortless panel operation. Stainless steel components ensure corrosion resistance.

Standard models available with:

- **Stainless steel** or **polymer** CNC engineered wheels
- 2.50" and 3.00" wheel diameter
- 1.10" adjustment range

Housing wing variants, wheel sizes and attachments available upon request.

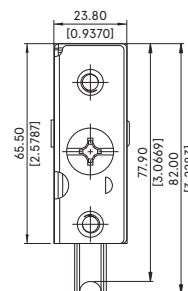
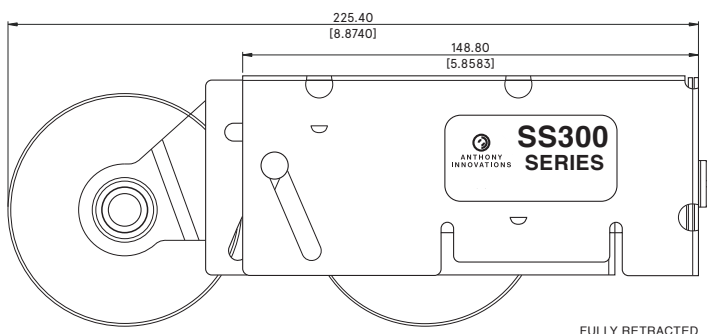

Manufacturer of
Verified Components